

I. I. Abramov and V. V. Kharitonov

UDC 621.382.82.001:519.95

Results of a two-dimensional numerical modeling of a single-collector I<sup>2</sup>L element with thermal effects taken into account are described.

Presented in this paper are results of investigating the influence of thermal effects on the current-voltage characteristics of a VLSI element with injection supply, executed by using a general-purpose program of a two-dimensional numerical analysis UNTEMP [1]. A single-collector I<sup>2</sup>L element A from [2], shown in Fig. 1 (the geometric dimensions of the structure being analyzed are given in  $\mu\text{m}$ ), was selected as illustration, and other parameters of the element are presented in it. The model dependences utilized in the computation and the process of constructing a discrete physicotopological model with thermal effects taken into account are described in [3].

## ISOTHERMAL CONDITIONS

Represented in Fig. 2 are data of machine restoration of the current-voltage characteristics of the element under investigation at the room temperature  $T_{\text{sm}} = 300$  K according to available initial information. The results were obtained by using the general purpose program of a two-dimensional numerical analysis of integral circuit elements PNAIIL [4]. Investigations were conducted for I<sup>2</sup>L element connection circuits in which an inverse mode of horizontal p-n-p transistor operation and a normal mode of vertical n-p-n transistor operation are realized. As is seen from the figure, the results of the modeling are in good agreement with the experimental data [2]. The estimated error of the current computation is 15-25%. These data confirm the fact that the other modeling results correspond to reality.

INFLUENCE OF SELF-HEATING ( $T_{\text{sm}} = 300$  K)

The next stage in the I<sup>2</sup>L-element investigation is analysis of self-heating at the  $T_{\text{sm}} = 300$  K temperature, performed by using the UNTEMP program [1].

Let us first note that the following iteration parameters and criteria were used in the method of [1]: 1) the Newton method iterations (Sec. 5 of the method) were performed only for  $S1 = 1$ , otherwise (12) of [1] is solved and the prediction for the concentration in Sec. 5 is not performed in the method; 2) the transfer to the solution of (18) in [1], i.e., to Sec. 12 of the method, is realized if the conditions  $\|\delta\psi^1\| \leq \varepsilon_1 + \varepsilon_2 \|\psi^{S1, S2}\|$ ,  $\|\delta n^1\| \leq \varepsilon_1 + \varepsilon_2 \|n^{S1, S2, 0}\|$ ,  $\|\delta p^1\| \leq \varepsilon_1 + \varepsilon_2 \|p^{S1, S2, 0}\|$  with the values  $\varepsilon_1 = \varepsilon_2 = 0.1$  are satisfied in Sec. 11; 3)  $NS3 = 1$  in Sec. 10; 4) the iterations are terminated (Sec. 14 of the method) when  $|\delta\psi^1|_{\text{max}} \leq 0.3 \cdot 10^{-2}$  in normalized units.

The expediency of utilizing such a simplified modification of the method is caused by several factors; 1) comparatively small magnitude of the self-heating (maximal values of  $\Delta T_{\text{max}} = 3-4$  K); 2) relatively low doping levels ( $\ll 10^{21} \text{ cm}^{-3}$ ); 3) large values of the electron and hole lifetimes in the active domains of the structure; 4) good quality of the initial approximation. A cyclic Chebyshev method [5] was used in solving the system of linear algebraic equations.

The first series of calculation experiments corresponds to the normal horizontal p-n-p transistor operation mode:  $V_i = V_{\text{ap}} > 0$  V, and  $V_b = V_c = V_e = 0$  V. The direct bias applied to the injector varied between broad limits  $V_{\text{ap}} \in [0.6 \text{ V}; 1 \text{ V}]$ . It turns out that the maximal amount of self-heating  $\Delta T_{\text{max}} = T_{\text{max}} - T_{\text{sm}}$  is small even for  $V_{\text{ap}} = 1$  V and is 0.195 K.

Belorussian Institute of Railroad Transport Engineers, Gomel. Translated from *Inzhenero-Fizicheskii Zhurnal*, Vol. 54, No. 5, pp. 823-828, May, 1988. Original article submitted November 20, 1986.

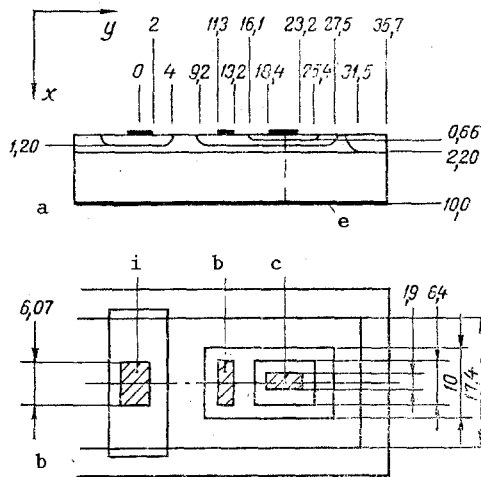

Fig. 1

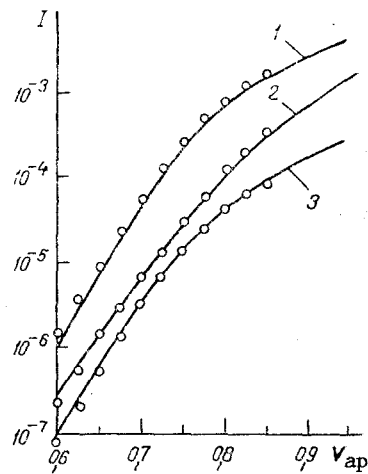

Fig. 2

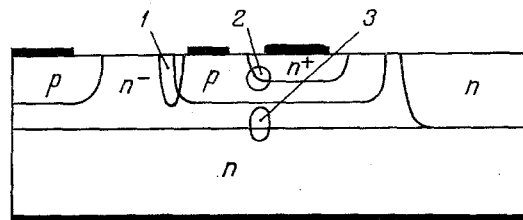

Fig. 3

Fig. 1. Functionally integrated element: a) vertical section of the structure in a plane marked by the dash-dots in Fig. 1b (e is the emitter contact); b) element topology (i, b, c are the injector, base, and the collector contacts).

Fig. 2. Results of machine restoration of the current-voltage characteristics [1] collector current; 2) base current; 3) injector current]: points are experimental data [2]; curves are machine restoration by using the PNAIIL program. I, A; V<sub>ap</sub>, V.

Fig. 3. Domain of maximal self-heating of the structural-technological VLSI modification under consideration: 1) normal mode of horizontal p-n-p transistor operation; 2) inverse mode of horizontal p-n-p transistor and normal mode of vertical n-p-n transistor operation; 3) inverse mode of vertical n-p-n transistor operation.

The maximal self-heating domain (1) of the I<sup>2</sup>L element in Fig. 3 corresponds to the domain of maximal values of the power density (for this structure and bias) at the emitter-base junction.

Taking account of self-heating for this operation mode does not influence the rate of convergence of the method. The total quantity of iterations for V<sub>i</sub> = 1 V was S<sub>1</sub> = 32, where in conformity with the above-mentioned criterion (18) from [1] started to be solved in 16 iterations. Analogous data in the number of iterations are obtained also for a similar method in the case of utilizing the PNAIIL program for corresponding identical model dependences and parameters.

The second series of calculation experiments corresponds to the inverse mode of horizontal p-n-p transistor and the normal mode of vertical n-p-n transistor operation, i.e., V<sub>b</sub> = V<sub>c</sub> = V<sub>ap</sub> > 0 V, V<sub>i</sub> = V<sub>e</sub> = 0 V. The values of V<sub>ap</sub> varied between 0.6 and 1 V. A graph of the changes in the quantity ΔT<sub>max</sub> as a function of V<sub>ap</sub> is presented in Fig. 4a (curve 1). It is seen that the maximal value of the self-heating is observed for V<sub>ap</sub> = 1 V and is already a greater quantity ΔT<sub>max</sub> ≈ 1.9 K. The corresponding domain of the I<sup>2</sup>L element (2 in Fig. 3) agrees with the domain of maximal values of the power density (for this structure and bias) at the collector-base junction closer to the base contact.

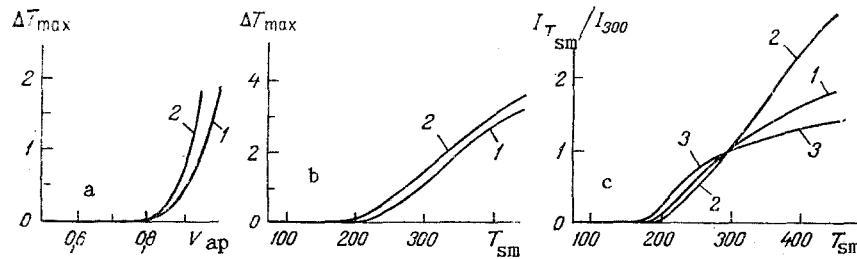

Fig. 4. Investigations of the influence of thermal effects: a) self-heating of an element at room temperature ( $T_{sm} = 300$  K): 1) change in  $\Delta T_{max}$  as a function of  $V_{ap}$  in the inverse mode of horizontal p-n-p transistor and normal mode of vertical n-p-n transistor operation; 2) change in  $\Delta T_{max}$  as a function of  $V_{ap}$  in the inverse mode of vertical n-p-n transistor operation; b) change in  $\Delta T_{max}$  as a function of  $T_{sm}$  1)  $V_b = V_c = 0.95$  V,  $V_i = V_e = 0$  V; 2)  $V_b = V_c = 0.975$  V,  $V_i = V_e = 0$  V; c) dependence of  $I_{T_{sm}}/I_{300}$  on  $T_{sm}$  for  $V_b = V_c = 0.95$  V,  $V_i = V_e = 0$  V for currents: 1) injector; 2) base; 3) collector.

The quantity of total iterations  $S_1$  for  $V_{ap} = 0.95$  V is 50, where (18) also started to be solved for  $S_1 = 16$ . For comparison we indicate that when using PNAIIL 43 iterations were required. However, the maximal quantity of self-heating is achieved for the inverse mode of vertical n-p-n transistor operation, i.e.,  $V_c = -V_{ap}$  ( $V_{ap} > 0$  V),  $V_i = V_b = V_e = 0$  V. A graph of the change  $\Delta T_{max}$  as a function of  $V_{ap}$  is shown in Fig. 4a (curve 2). The quantity  $\Delta T_{max}$  equals  $\sim 1.8$  K for  $V_{ap} = 0.95$  V in this case. For comparison we indicate that for the mode considered above it is  $\sim 1$  K for  $V_{ap} = 0.95$  V, i.e., approximately half. The domain of the maximal magnitude of self-heating (3 in Fig. 3) also corresponds to the domain of maximal values of  $Q_T$  for this structure and bias. In this case it is in the epitaxial n<sup>-</sup>-layer under the collector edge nearer to the base contact.

The influence of self-heating on the current-voltage characteristics is not large in all the cases considered. Thus, for the inverse mode of horizontal p-n-p transistor and the normal mode of vertical n-p-n transistor operation it was less than 1%. The solution was obtained for all cases on a mesh with  $25 \times 74$  nodes. The mean time of completing one full iteration for the ES-1060 computer was 30-40 sec.

The self-heating effect increases with the rise in the doping level (influences the field intensity  $E$  in the p-n junctions), the direct (influences the total current density  $j_T$ ) and reverse biases (influences  $E$ ); however, the maximal self-heating domains correspond to those mentioned above for elements of the considered structural-technological modification and operating modes. On the whole, by using similar investigations, domains critical to the influence of self-heating can be determined easily for different structural-technological modifications of VLSI elements and their operating modes. This information is of great value for structure optimization.

#### INFLUENCE OF THE TEMPERATURE OF THE SURROUNDING MEDIUM

As the results of a multidimensional numerical modeling show, the most important thermal effect on an I<sup>2</sup>L element is caused by the influence of the temperature of the surrounding medium. As an illustration the current-voltage characteristics of the structure under investigation was computed in the inverse mode of horizontal p-n-p transistor and the normal mode of vertical n-p-n transistor operation for eight values of the  $T_{sm}$  temperature: 77 K, 100, 200, 250, 300, 350, 400, 450 K.

It turns out that the temperature of the surrounding medium exerts a sufficiently strong influence on self-heating of the element. Shown in Fig. 4b are graphs of changes in the quantity  $\Delta T_{max}$  as a function of  $T_{sm}$  that illustrate this effect. Thus, for temperatures of 77, 100, 200 K and the self-heating can be neglected in the whole range of biases (up to  $V_b = V_c = V_{ap} = 0.975$  V,  $V_i = V_e = 0$  V). However, for  $T_{sm} = 450$  K this effect is already of a significant magnitude  $\Delta T_{max} \approx 3.5$  K for  $V_{ap} = 0.975$  V and  $\Delta T_{max} \approx 3.9$  K for  $V_{ap} = 1$  V. Therefore, as  $T_{sm}$  grows the self-heating effect is magnified, which is caused by the growth of the current densities flowing in the structure.

Just as significant is the influence of the temperature of the surrounding medium on the current-voltage characteristic also (Fig. 4c). It is seen that at low temperatures ( $T_{sm} = 77$  and  $100$  K) the ratio between the current flowing through the contact and its value at room temperature ( $T_{sm} = 300$  K) is close to 0.

A consequence of very low current values is also an extremely rapid (quadratic) convergence of the iterations. Thus, for instance, for  $V_{ap} = 0.95$  V the solution was obtained after just two complete iterations where  $|\delta\psi^1|_{max}$  varies between 5 and  $0.7 \cdot 10^{-4}$  (in normalized units). The sufficiently high quality of the initial approximation examined in [1] is thereby illustrated.

As the temperature rises, as is seen from Fig. 4c, rapid growth occurs of the ratio  $|I_{T_{sm}}/I_{300}|$ . Thus for  $T_{sm} = 450$  K the base current is magnified 2.9 times as compared with the current at  $T_{sm} = 300$  K, the collector current 1.4 times, and the injector current 1.8 times. At the same time the total quantity of iterations in this operating mode is significant and equal to 84 for  $V_{ap} = 0.95$  V.

Therefore, it is seen from the results presented that the dominant thermal effect on the I<sup>2</sup>L element under investigation is caused by the influence of the temperature of the surrounding medium.

#### NOTATION

$x, y$ , space coordinates;  $T_{sm}$ , temperature of the surrounding medium;  $S1, S2$ , numbers of iterations of the first and second stages of the VRS mode of operation [1];  $\psi^{S1, S2}$ ,  $n^{S1, S2, 0}$ , values of the electrostatic potential, the electron and hole concentrations at the corresponding iterations of the VRS method denoted by the superscripts [1];  $\delta\psi^1, \delta n^1, \delta p^1$ , corrections to the electrostatic potential, the electron and hole concentrations [1];  $|\delta\psi^1|_{max}$ , maximal value of  $|\delta\psi_j^{i, 1}|$ , where  $i, j$  are numbers of the mesh nodes;  $V_i, V_b, V_c, V_e$ , voltages applied to the injector (i), base (b), collector (c), and emitter (e) contacts;  $V_{ap}$ , applied voltage;  $T_{max}$ , maximal value of the temperature within the element;  $Q_T$ , power density liberated in the element; and  $I_{T_{sm}}, I_{300}$ , values of the currents flowing through the contacts at the temperatures  $T_{sm}$  and 300 K.

#### LITERATURE CITED

1. I. I. Abramov and V. V. Kharitonov, *Inzh.-Fiz. Zh.*, 54, No. 3, 493-499 (1988).
2. K. Hanikharu, H. Yanai, and T. Kamiya, *IEEE Trans.*, ED-29, No. 3, 418-430 (1982).
3. I. I. Abramov and V. V. Kharitonov, *Inzh.-Fiz. Zh.*, 54, No. 2, 309-314 (1988).
4. I. I. Abramov and V. V. Kharitonov, *Inzh.-Fiz. Zh.*, 51, No. 1, 136-143 (1986).
5. D. Potter, *Computational Methods in Physics* [Russian translation], Moscow (1975).